

LIGHT/AERIAL BRACKET INSTRUCTIONS

ASSEMBLY INSTRUCTIONS FOR PR3076

KIT CONTAINS

1 x Instructions	2 x M6 T-Slot Nuts
1 x Light Bracket	2 x M8 Spring Nuts
2 x M6x12mm Screws	1 x 4mm Allen Key
2 x M8x25mm Screws	
2 x M6x16mm Washers	
2 x M6 Spring Washers	
2 x M8x17x1.2mm Washers	

Remove parts from box and check.
Contact your Prorack Dealer if any parts are missing or damaged.

INSTALLATION TO STANDARD T-SLOT CROSSBARS



T-Slot Crossbars, similar to this



Select two T-Slot nuts from the package.
Press crossbar infill down and fit both T-Slot nuts
into crossbar on top of infill.



T-Slot nuts should be positioned on a
crossbar in a place where you want your
bracket located.



Use 4mm Allen key to attach bracket to T-Slot nuts with M6 screws. Ensure the spring washers are placed on top of the normal M6 washers.



Completely assembled Light/Aerial bracket on Crossbar.

INSTALLATION TO HD T-SLOT CROSSBARS



T-Slot Crossbars, similar to this

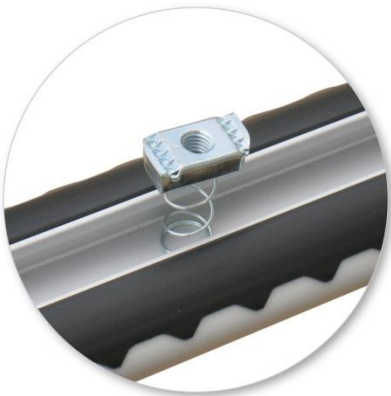

Select two Spring nuts from the package. Fit both Spring nuts into crossbar channel.



Spring nuts should be positioned on a crossbar in a place where you want your bracket located. Push down and twist spring nut to lock into place.



Use a spanner to attach bracket to Spring nuts
With M8 screws.
Ensure M8 washers are placed between bracket
and screws.



Completely assembled Light/Aerial Bracket
on crossbar.

WARRANTY AND DISCLAIMER

Yakima Australia Pty Ltd ABN 58 154 440 221

17 Hinkler Court, Brendale QLD 4500

Tel: 0800 4776 722 (NZ) or 1800 143 548 (AU) Email: warranty@yakima.co.nz or warranty@yakima.com.au

1. Where the product is supplied to the customer for other than business purposes within the meaning of section 43 of the New Zealand Consumer Guarantees Act 1993, the provisions of that Act shall apply. It is important that anyone who fits or uses this product does so in accordance with the manufacturer's instructions.
2. Where the product is supplied to the customer for business purposes within the meaning of section 43 of the New Zealand Consumer Guarantees Act 1993, the provisions of that Act and all other representations or terms (including any conditions or warranty expressed or implied by law, statute or otherwise) not expressly included in this leaflet are hereby expressly excluded shall have no effect and the clauses (a) and (b) shall apply.
3. Subject to the Additional Information (Australia), where the product is supplied and purchased in Australia, the following shall apply:
 - (a) THE SUPPLIER WARRANTS the product to be free from defects in materials and/or workmanship for a period of three (3) years from the date of original purchase (the warranty period). Proof of purchase is required. Subject to the limitations and exclusions set out below, the Supplier hereby agrees to remedy any defects in materials or workmanship becoming apparent during the warranty period, by replacing or repairing any defective product or component (at its option) free of charge to the purchaser in respect of replacement parts or labour. Any defective product or component must be notified and where practicable, returned at the purchaser's expense to the Supplier immediately upon discovery of the alleged defect and no attempt made on the part of the purchaser to repair it.
 - (b) EXCEPTIONS, EXCLUSIONS AND LIMITATIONS TO WARRANTY. The product and/or its components must be fitted/assembled and loaded in accordance with the Supplier's written instructions and any requirements set out in the car's owner manual. This warranty does not cover defects, loss or damage resulting from circumstances beyond the Supplier's control including, but not limited to misuse, overloading, or failure to assemble and/or fit the product or component in accordance with the Supplier's written instructions. Nor does the warranty cover defects, loss or damage resulting from accidents, unlawful use of the vehicle or defects/inconsistencies in the vehicle on which the product or component is fitted. Liability for direct, indirect, special, punitive, incidental, exemplary, contractual or consequential damage or loss arising from defects, faulty materials or design omissions or negligence or workmanship in the product or its components is hereby expressly excluded subject to the following. Certain Commonwealth legislation, including the Competition and Consumer Act 2010 (Cth), and other State and Territorial legislation confers upon purchasers rights which cannot be excluded from or be restricted or modified by contract. Any conditions, guarantees and/or warranties implied by law and incapable of exclusion are deemed to be expressly incorporated herein. Nothing herein contained is intended nor shall be permitted to be inconsistent with any such conditions, guarantees and/or warranties. To the extent permitted by legislation all conditions, guarantees and/or warranties such as implied warranties which are capable of exclusion are hereby expressly excluded and negated.

ADDITIONAL INFORMATION (AUSTRALIA)

This information should be read in conjunction with clauses (a) and (b).

IMPORTANT LEGAL NOTICE

Our goods come with guarantees that cannot be excluded under the Australian Consumer Law. You are entitled to a replacement or refund for a major failure and for compensation for any other reasonably foreseeable loss or damage. You are also entitled to have the goods repaired or replaced if the goods fail to be of acceptable quality and the failure does not amount to a major failure.

This warranty does not change or take away your rights under the Australian Consumer Law. Your right to claim under this policy for the benefits covered is in addition to other rights and remedies you have under the law in relation to the product.

Where you become aware of defects in materials or of workmanship, and wish to make a claim under this warranty you must do the following for the warranty to be honoured by your Prorack dealer or Yakima Australia Pty Ltd ABN 58 154 440 221 (Yakima):

1. Make a claim as soon as practicable by contacting the Prorack dealer from whom you purchased the product, who will give you instructions on how to proceed.
2. If you are unable to contact the Prorack dealer, or the dealer is not able to remedy the defect, you should contact Yakima as soon as practicable at:

Call: 0800 4776 722 (NZ) or 1800 143 548 (AU)

Email: warranty@yakima.co.nz or warranty@yakima.com.au

Alternately, you can write to Yakima at 17 Hinkler Court, Brendale QLD Australia 4500 in order to make a claim under your warranty.

3. Upon contacting Yakima directly, you should explain as fully as possible the defect. A Yakima representative will provide you with appropriate instructions for returning the product together with a copy of the original purchase invoice or receipt to Yakima.
4. The costs and expenses associated with making a claim under your warranty including the costs of complying with those instructions and of returning the product to Yakima or the Prorack dealer will be borne by you.

Following receipt of the product and purchase invoice or receipt, Yakima or the Prorack dealer must inspect the product to determine whether the claim falls within the warranty. If:

- 4.1 the claim falls within the warranty, Yakima will remedy any defects in materials or workmanship becoming apparent during the warranty period, by replacing or repairing any defective product or component (at its option) free of charge to the purchaser in respect of replacement parts or labour.
- 4.2 the claim does not fall within the warranty, Yakima will return the product to you at your expense.

Yakima Australia Pty Ltd
17 Hinkler Court
Brendale
Brisbane 4500
Australia

Freephone New Zealand:
0800 477 6722

Freephone Australia:
1800 143 548